

Attachment C
October 1, 2020 Staff Report

REQUEST FOR HISTORIC AND SCENIC PRESERVATION COMMISSION ACTION

VI.A. REDLANDS PALM INVESTMENT, LLC, APPLICANT

A review of the Cultural Resources Assessment/Historic Resource Evaluation related to Tentative Parcel Map No. 20185, Tentative Tract Map No. 20305, and Conditional Use Permit No. 1143 for the subdivision of an 8.8-acre parcel located at 301 W. Palm Avenue to develop a Planned Residential Development with a total of 30 new residential lots for new single-family development in the R-S, Suburban Residential District. The historic resources evaluation assessed the following extant features: the existing England/Attwood Estate house, Carriage House, Grove Barn, and England Cottage located at 301 W. Palm Ave.; the existing single-family residence located at 827 Alvarado St.; and associated remnant citrus grove, gravity irrigation system, and stone wall along a portion of the property boundary. The project is subject to the California Environmental Quality Act, and an Initial Study/Mitigated Negative Declaration was prepared in accordance with Sections 15072, 15073, and 15074 of the CEQA Guidelines.

HISTORIC AND SCENIC PRESERVATION MEETING: OCTOBER 1, 2020

Planner: Sean Reilly, Senior Planner

SYNOPSIS

1. Historic Designation: The property is not designated as historic by the City of Redlands, the State of California, or the United States Government.
2. Existing Land Use: The site is approximately 8.8-acres and is occupied by two single-family residences, accessory structures and an orange grove.
3. Historic and Scenic Preservation Commission submittal dates:

(A) Date Submitted:	December 11, 2019
(B) Date Accepted as Complete:	June 24, 2020
(C) Historic and Scenic Preservation Commission Meeting:	October 1, 2020
4. Attachments:
 - (A) Location Map
 - (B) Site Aerial Photograph
 - (C) Tentative Parcel Map No. 20185
 - (D) Tentative Tract Map No. 20305
 - (E) Project Landscape Plans
 - (F) Cultural Resources Assessment and Historical Resources Evaluation
 - (G) Initial Study/MND

PROJECT DESCRIPTION

The applicant, Redlands Palm Investment, LLC, is proposing to subdivide an 8.8-acre parcel located at 301 W. Palm Avenue to develop a planned residential development. Referred to as the England/Attwood Estate, the property is located at the westernmost corner of Palm Avenue and Alvarado Street in the southern portion of the City (Attachments A and B). Currently the parcel is occupied by an orange grove, two single family homes, and accessory structures associated with the homes and the operation of the grove.

The applicant's proposal includes a Tentative Parcel Map No. 20185 to first subdivide the single parcel into four parcels as detailed below.

- Parcel 1: This parcel will contain England House and the associated carriage house. The England house parcel located at 301 W. Palm Avenue will be approximately 1.5 acres in size and will have independent access from Palm Avenue. The landscaping and structures within this parcel will be maintained in place by the Project. It is the applicant's intent to utilize this parcel as a part of the requirement to provide 20% of the gross land area as, common, landscaped, recreational open space for the Project. As such, Staff is including a Condition of Approval on the Project requiring local historic designation of this parcel. The historic designation application will be presented to the Historic and Scenic Preservation Commission (HSPC) at a later date as a public hearing item for a recommendation to the City Council.
- Parcel 2: The England cottage located at 827 Alvarado Street will be contained within Parcel 2 which is approximately 0.45 acres in size with access from Alvarado Street. An existing garage to the located south of the existing residence on this parcel will be demolished as a part of the Project. The demolition of this structure is discussed later in this report.
- Parcel 3: An approximately 0.85-acre park is proposed to be located at the corner of Palm Avenue and Alvarado Street. The park would include walkways, seating areas, and a large tree within a raised planter adjacent to a plaza oriented towards the corner of West Palm Avenue and Alvarado Street. The Project applicant would retain the existing grove of orange trees along the northeast and southeast edges of the park space. The applicant would develop the open space, which would be owned and maintained by the Homeowner's Association (HOA) of the future subdivision on Parcel 4. The Project Landscaping Plan included as Attachment C shows the proposed landscaping of the Project site, including the landscaping of the open space, as well as the landscaping that would be maintained on Parcel 1 and Parcel 2 of the Project.

- Parcel 4: The approximately six-acre remaining portion of the site would then be further subdivided into to 30 single-family residential lots by Tentative Tract Map No. 20305-PRD. Homes planned for each of the 30 lots would be single-story. Access to this portion of the Project would from be a new street located off of West Palm Avenue approximately 500 feet northeast of the West Palm Avenue/Alvarado Street intersection. A second gated emergency vehicle access to the Project would be provided off Alvarado Street, approximately 530 feet southeast of the West Palm Avenue/Alvarado Street intersection. The internal circulation system of the proposed Project would include one residential street extending from the entrance off West Palm Avenue and ending in a cul-de-sac at a gated emergency access point off of Alvarado Street. Four lettered lots (Lots A-D) are provided for landscaping along the parcel's perimeter. An existing shed on this parcel, located to the south of the existing carriage house on Parcel 1, will be demolished as a part of the Project. The demolition of this structure is discussed later in this report.

The proposed Tentative Parcel Map and Tentative Tract Map have been included as Attachment D and Attachment E. The Project is tentatively scheduled to go before the Planning Commission on October 27, 2020. The Project requires the discretionary approvals listed below.

- Approval of a Tentative and Final Parcel Maps
- Approval of Tentative and Final Tract Maps
- Conditional Use Permit (CUP) for a Planned Residential Development (PRD)
- A variance to allow a reduction in the front yard setbacks
- A variance to reduce the amount of required rear yard open space.
- Demolition permits for the removal of two non-contributing accessory structures
- Minor Exception Permit for the construction of walls and fences exceeding six feet tall and walls and fences exceeding the maximum allowable height within front yard setbacks.

BACKGROUND

The applicant submitted the Project on December 11, 2019. At that time, the applicant also submitted a Cultural Resources Assessment and Historical Resources Evaluation (CRA) prepared by BCR Consulting. A copy of this report is included as Attachment F. In accordance with City Council Resolution 7744, the City (at the applicant's expense) retained LSA Associates to prepare an Initial Study/Mitigated Negative Declaration (IS/MND) as required by the California Environmental Quality Act (CEQA). A copy of the IS/MND is included as Attachment G.

LSA Associates provided a professional peer review of the CRA. The CRA was then used to prepare and provide an analysis of potential impacts to cultural resources within the IS/MND. The IS/MND was prepared and circulated from August 20, 2020 to September 9, 2020. Multiple comments were received from the public on the project during the review period. Several of these comments pertain to the Cultural Resources section of the IS/MND.

The property consists of multiple components associated with the existing grove, most significant among them being two residential buildings, a carriage house, detached garage, and a grove barn. Other historic components include a gravity-fed water system, a concrete irrigation weir, stone masonry curbing, a concrete incinerator, and historic landscape featuring palms and orange groves. Originally developed as a rural-residential complex in 1891, the property has retained much of its original character and several of the comments from the public on the IS/MND refer to these features.

The CRA prepared for the Project states that the England/Attwood Estate is eligible for listing in the California Register as a historic district, and that Criterion 1, 2, and 3 for the California Register of Historic Resources can be met. The report states that resource retains integrity of location, setting, design, materials, workmanship, feeling, and association. The table below is taken from the CRA and lists the contributing and non-contributing resources to the potential historic district.

Table 1: Contributing and Non-contributing Resources

Resource	Year Built	Contributor/Non-contributor
England House	1891/1915	Contributor to the potentially-eligible England/Attwood Estate under Criteria 1, 2, & 3
England Cottage	1893	Contributor to the potentially-eligible England/Attwood Estate under Criteria 1, 2, & 3
Carriage House	1891	Contributor to the potentially-eligible England/Attwood Estate under Criteria 1, 2, & 3
Grove Barn	c1908	Non-contributor, utilitarian building is a replacement of original Grove Barn and lacks architectural or historical significance
Orange Grove/Landscape	1890s	Contributor to the potentially-eligible England/Attwood Estate under Criteria 1, 2, & 3
Gravity-Fed Irrigation System and Weir	1890s	Contributor to the potentially-eligible England/Attwood Estate under Criteria 1, 2, & 3
Detached Garage at England Cottage	1942	Non-contributor, constructed outside the period of significance, altered outside the historic period
Boundary Footing/Fence	unknown	Non-contributor, unknown construction date, altered outside the historic period

Prior to presenting the Project to the Planning Commission, Staff believes it is important to present both the CRA and the IS/MND to the Historic and Scenic Preservation Commission (HSPC) for discussion and a response to the following question.

Does the evaluation of Cultural Resources in the Initial Study/Mitigated Negative Declaration, based on the Cultural Resources Assessment/Historic Resources Evaluation technical report, adequately identify all impacts to cultural and historic resources by the proposed project and include adequate mitigation measures to mitigate all identified impacts to a level of less-than-significant?

SUMMARY OF IMPACTS

The Cultural Resources section of the IS/MND analyzed the Project as it relates to three questions as required by CEQA. The questions are listed below along with summarized responses based on the contents of the IS/MND and CRA.

Question 1: Would the project cause a substantial adverse change in the significance of a historical resource pursuant to Section 15064.5?

In regard to potential impacts to historical resources as described in question one, the CRA prepared for the Project states that the England/Attwood Estate is eligible for listing in the California Register and that three of the four criteria for the California Register of Historic Resources can be met (Criterion 1, 2 and 3). The report states that this historic resource retains integrity of location, setting, design, materials, workmanship, feeling and association. The four criteria are listed below.

1. It is associated with events that have made a significant contribution to the broad patterns of local or regional history, or the cultural heritage of California or the United States; or
2. It is associated with the lives of persons important to local, California, or national history; or
3. It embodies the distinctive characteristics of a type, period, region, or method or construction, or represents the work of a master, or possesses high artistic values; or
4. It has yielded, or has the potential to yield, information important to the prehistory or history of the local area, California, or the nation.

The report also recommends that the England/Attwood Estate is eligible for listing as a City Historic District under Redlands Criterion A, C, D, G, I, and J. The full list of Criteria

can be found in Section 2.62.170 of the Redlands Municipal Code. Applicable portions are listed below.

- A. It has significant character, interest, or value as part of the development, heritage or cultural characteristics of the city of Redlands, state of California, or the United States;
- C. It is strongly identified with a person or persons who significantly contributed to the culture, history or development of the city;
- D. It is one of the few remaining examples in the city possessing distinguishing characteristics of an architectural type or specimen;
- G. It has a unique location or singular physical characteristics representing an established and familiar visual feature of a neighborhood, community, or the city;
- I. It is a particularly good example of a period or style;
- J. It contributes to the historical or scenic heritage or historical or scenic properties of the city (to include, but not be limited to, landscaping, light standards, trees, curbsings, and signs);

Based on these findings, the assessment concludes that the estate would be considered a historic resource under the CEQA.

A “substantial adverse change” to a historical resource, according to Public Resources Code (PRC) §5020.1(q), “means demolition, destruction, relocation, or alteration such that the significance of a historical resource would be impaired.”

Construction of the project would require the removal of the boundary footing/fence, the gravity-fed irrigation system and weir, and portions of the grove. The removal of these items would not require a demolition permit. The fence/footing is considered to be a non-contributor to the potential historic district based on the CRA. However, the irrigation features and the grove are considered to be contributing. The grove barn and the detached garage at the England cottage would also be removed. These structures are also considered to be non-contributors to the potential historic district based on the CRA, but Demolition Permits would be required as discussed below. Elements of the property that will remain are the England house, the England cottage, the England carriage house, and portions of the orange groves. The CRA discusses these features in relation to the Secretary of the Interior’s Standards for the Treatment of Historic Properties.

The Secretary of the Interior’s Standards for the Treatment of Historic Properties provide guidelines for the preservation and rehabilitation of historic resources.

Adherence to these standards is accepted as a method of avoiding significant adverse effects to historic buildings while allowing their continued use.

The CRA provides a detailed analysis and concludes that the project is consistent with the Secretary of the Interior's Standards and therefore, the project has a less than significant impact in relation to historical resources and no mitigation is required.

The analysis in the CRA states that the distinctive spatial relationships between the contributing buildings and landscape features in their immediate vicinity will be maintained and that while the removal of the trees northeast of the main residence along Palm Avenue will produce a visible change to the setting, the mature orange trees will be preserved on the parcels that will hold the historic buildings as well as at the corner of Palm Avenue and Alvarado Street. Therefore, the appearance of the orchard from Palm Avenue and Alvarado Street will be only moderately altered. It states that the most important trees are those that provide the immediate aesthetic setting for the historic buildings on Parcel 1 and 2, which will be retained. One contributing feature of the property, the irrigation system/weir, will be demolished by the project. The CRA calls this a functional feature that is not visible from the public right-of-way. The CRA concludes that the historic character of the property will therefore be retained and preserved despite the loss of a portion of the orchard and of the historic irrigation system.

Further discussion and a complete analysis is provided in the CRA included as Attachment F and the IS/MND included as Attachment G.

In the Cultural Resources section of the IS/MND, there are mitigation measures listed related to historical resources. These mitigation measures came about through the AB-52 consultation process with local Native American tribes. Due to the proximity of the Project to Native American sites, there is some potential for the proposed project to unearth previously undocumented cultural resources during construction. The mitigation measures require a Registered Professional Archaeologist to be onsite to monitor all ground disturbing activities and they describe the requirements for treatment, documentation and reporting in the event that there is a discovery during construction. The IS/MND concludes that with the implementation of these mitigation measures, impacts would be reduced to a level that is less than significant.

Question 2: Would the project cause a substantial adverse change in the significance of an archaeological resource pursuant to 15064.5?

The IS/MND concludes that with the implementation of the mitigation measures, which require archaeological monitoring, impacts related to archaeological resources would be reduced to a level that is less than significant.

Question 3: Would the project disturb any human remains, including those interred outside of formal cemeteries?

There are no known human remains present onsite. However, due to the proximity of the Project to known Native American sites, Cultural Resource mitigation measures been included in the IS/MND requiring archaeological monitoring. The IS/MND concludes that with the implementation of these mitigation measures, impacts related to the discovery of human remains will be reduced to a level that is less than significant.

DEMOLITION PERMITS

As a part of the Project, the applicant is proposing to demolish two structures on the property. As these structures are over 50 years of age, they are required by the Municipal Code to be reviewed by the Historic and Scenic Preservation Commission (HSPC) prior to the issuance of a demolition permit. The first structure that is proposed to be demolished is a detached 1-car garage located within Parcel 2, the England cottage (827 Alvarado Street). This garage is located to the south of the England cottage adjacent to Alvarado Street and is a simple, rectangular structure constructed with shiplap siding, composition shingle roofing, and a contemporary garage door. The garage was constructed outside of the period of significance and has been altered outside of the historic period. For these reasons, this structure is not considered to be contributor to the potential historic district based on the findings of the CRA.

The second structure is a building referred to as the “grove barn” or the “England Estate Utility Barn” in the CRA. The grove barn is located south of the carriage house located in the center of the property. It is a utilitarian structure constructed with a wood frame and stone foundation with corrugated metal siding, doors and roofing. It is a replacement of the original barn structure once on the property and it lacks architectural and historical significance for these reasons it is not considered to be a contributor to the potential historic district based on the findings of the CRA.

Demolition permits will be required by Conditions of Approval placed on the Project prior to their removal and these applications will be scheduled to come back before the HSPC as a public hearing item at a later date.

RECOMMENDATION:

Staff requests that the HSPC review and discuss the IS/MND and the CRA prepared for the project and provide a recommendation to the Planning Commission on whether these documents adequately identify all impacts to cultural and historic resources and include adequate mitigation measures to mitigate all identified impacts to a level of less-than-significant.

References

BCR Consulting, LLC., Cultural Resources Assessment and Historical Resources Evaluation 310 West Palm Avenue, July 16, 2020.

LSA Associates, Initial Study/Mitigated Negative Declaration, 301 Palm Avenue Residential Development Project, August 2020.

Attachment A

Location Map



This map was produced by the City of Redlands, Geographic Information System. The City of Redlands assumes no warranty or legal responsibility for the information contained on this map. The data used to generate this map is dynamic in nature, therefore the information shown may or may not be the most current.

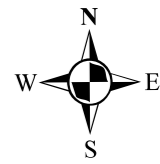

September 17, 2020

OneStop.mxd

Attachment B

Aerial Photo



This map was produced by the City of Redlands, Geographic Information System. The City of Redlands assumes no warranty or legal responsibility for the information contained on this map. The data used to generate this map is dynamic in nature, therefore the information shown may or may not be the most current.

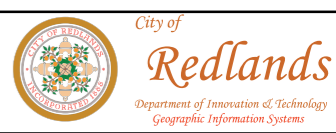
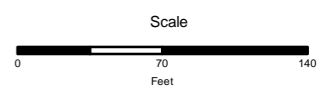
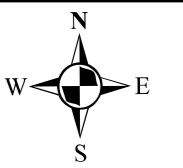

September 17, 2020

OneStop.mxd

Attachment C

TENTATIVE PARCEL MAP No. 20185

CITY OF REDLANDS, CALIFORNIA

APN 0173-231-05 (301 WEST PALM AVENUE)

APPLICANT
 DIVERSIFIED PACIFIC COMMUNITIES
 10621 CIVIC CENTER DRIVE
 RANCHO CUCAMONGA, CA 91730
 PH: (909) 481-1150
 FAX: (909) 481-1151

CIVIL ENGINEER
 HICKS & HARTWICK, INC.
 37 EAST OLIVE AVE., SUITE C
 REDLANDS, CA 92373
 PH: (909) 793-2257

MAP PREPARED BY:

 37 East Olive Ave., Ste C
 Redlands, CA 92373
 909.793.2257



GENERAL NOTES

- TOTAL PROJECT GROSS AREA: 383,773 SF (8.81 AC)
- PROJECT CONSISTS OF APN: 0173-231-05
- NUMBER OF PARCELS: 4
- DATE PREPARED: 11-15-19
- NET DEVELOPMENT AREA: 383,736 SF (8.81 AC)

REQUIREMENTS FOR PARCEL MAPS

- PER CITY OF REDLANDS DEVELOPMENT APPLICATION (JANUARY, 2019)
- DATE OF MAP PREPARATION: 10-01-2019
 - NORTH ARROW DELINEATED ON MAP AS REQUIRED
 - SCALE USED: 1" = 50'
 - ADJACENT SUBDIVISION INFO: DELINEATED ON MAP AS REQUIRED
 - INFORMATION DELINEATED ON MAP AS REQUIRED
 - EASEMENTS AND RIGHTS OF RECORD PER PRELIMINARY REPORT PREPARED BY CHICAGO TITLE COMPANY, NO. 7101407137-DA DATED 10-23-2018.
 - DELINEATED ON MAP AS REQUIRED
 - STATEMENT AS TO THE INTENTION IN REGARD TO SLOPE PLANTING AND EROSION CONTROL: N/A
 - VICINITY MAP: DELINEATED ON MAP
 - CONTOUR INTERVAL: 1' CONTOURS
 - ALL EXISTING STRUCTURES AND TREES TO BE REMOVED: DELINEATED ON MAP AS REQUIRED
 - LOCATION OF ALL AREAS OF POTENTIAL STORMWATER OVERFLOW; THE LOCATION, WIDTH AND DIRECTION OF FLOW: DELINEATED ON MAP
 - FEMA PANEL: PANEL 8716 OF 9400 PER FLOOD INSURANCE RATE MAP: 06071C8716H, AUGUST 28, 2008
 AREA DESIGNATION: ZONE X
 (AREAS DETERMINED TO BE OUTSIDE THE 0.2% ANNUAL CHANCE FLOODPLAIN)

EXHIBIT REQUIREMENTS - PART ONE

- PER CITY OF REDLANDS DEVELOPMENT APPLICATION (JANUARY, 2019)
- INDEX MAP ON ALL SHEETS: DOES NOT APPLY
 - NAME AND ADDRESS OF OWNER/APPLICANT/MAP PREPARER: DELINEATED ON MAP AS REQUIRED
 - ACREAGE, NORTH ARROW, VICINITY MAP, DATE OF PREPARATION: DELINEATED ON MAP AS REQUIRED
 - EXISTING STRUCTURES AND FEATURES SUCH AS WALLS, BUILDING, AND TREES: DELINEATED ON MAP AS REQUIRED
 - DIMENSIONS AND PROPERTY LINES FOR EACH LOT: DELINEATED ON MAP AS REQUIRED
 - NAMES OF ADJOINING SUBDIVISIONS AND LANDOWNERS AND ABUTTING LAND UNITS: DELINEATED ON MAP AS REQUIRED
 - LANDS DEDICATED FOR PUBLIC USE: DELINEATED ON MAP AS REQUIRED
 - POINTS OF INGRESS AND EGRESS: PALM AVENUE & ALVARADO STREET
 - PRELIMINARY GRADING, INCLUDING PAD ELEVATIONS AND FLOW LINES WITH LOCATION OF ALL CUT AND FILL SLOPES IDENTIFIED: DELINEATED ON MAP AS REQUIRED

EXHIBIT REQUIREMENTS - PART TWO

- PER CITY OF REDLANDS DEVELOPMENT APPLICATION (JANUARY, 2019)
- LOCATIONS, NAME, AND WIDTH OF STREETS AND ADJACENT STREETS ALSO SHOW WIDTH OF ALLEYS IF APPLICABLE: DELINEATED ON MAP AS REQUIRED
 - PROPOSED STREET GRADES AND GRADES FOR STREETS 100 FEET BEYOND APPLICANTS PROPERTY: DELINEATED ON MAP AS REQUIRED
 - CROSS SECTION OF PROPOSED STREET IMPROVEMENTS IF DIFFERENT FROM STANDARD: DELINEATED ON MAP AS REQUIRED
 - LOCATION, DIMENSION, AND PURPOSE OF ANY EASEMENT ON AND ADJACENT TO PROJECT SITE: DELINEATED ON MAP AS REQUIRED
 - LOCATION OF EXISTING PUBLIC UTILITIES, CULVERTS, DRAIN PIPES, AND WATER COURSES: DELINEATED ON MAP AS REQUIRED
 - APPROXIMATE RADIUS OF CURVES: DELINEATED ON MAP AS REQUIRED
 - TOPOGRAPHICAL DATA TO MAKE CLEAR THE EFFECT OF THE PROPOSAL: 2' CONTOURS AT GRADES 5% OR LESS, 5' CONTOURS AT GRADES OF MORE THAN 5%. SOURCE OF THE CONTOURS SHALL BE STATED ON MAP: DELINEATED ON MAP AS REQUIRED.

BENCH MARK

CITY OF REDLANDS BENCH MARK R-82, BRASS DISK IN TOP OF CURB AT THE SE CORNER OF CAJON STREET AND PALM AVENUE, EAST END OF RETURN. ELEVATION = 1317.581

BASIS OF BEARINGS

THE BASIS OF BEARINGS FOR THIS MAP IS DERIVED FROM THE CENTERLINE OF PALM AVENUE SHOWN AS N56°20'00"E ON TRACT NO. 6640, MB 84/6-7.

TOPOGRAPHIC MAP NOTE

TOPOGRAPHIC MAP PREPARED BY: INLAND AERIAL SURVEYS, INC.

SOILS ENGINEER / GEOLOGIST

GEOLOGICAL INVESTIGATION CONDUCTED BY: PETRA GEOSCIENCES INC. JOB NO. 18-430, DATED FEBRUARY 15, 2019

PUBLIC UTILITY COMPANIES

- GAS:**
 SOUTHERN CALIFORNIA GAS CO.
 1981 W. LUGONIA AVENUE
 REDLANDS, CA 92374-9720
 (800) 427-2200
- WATER:**
 CITY OF REDLANDS
 P.O. BOX 6908
 REDLANDS, CA 92375-0903
 (909) 798-7516
- ELECTRIC:**
 SOUTHERN CALIFORNIA EDISON CO.
 287 TENNESSEE STREET
 REDLANDS, CA 92373
 (909) 307-6731
- SEWER:**
 CITY OF REDLANDS
 P.O. BOX 6905
 REDLANDS, CA 92375-0903
 (909) 798-7516
- CABLE:**
 TIME WARNER CABLE
 1722 GRANGE TREE LANE
 REDLANDS, CA 92373
 (909) 793-2321
- TELEPHONE:**
 VERIZON INC.
 1500 CRAFTON AVENUE
 MENTONE, CA 92359
 (909) 794-8210

EASEMENTS AND RIGHTS
 EASEMENTS AND RESTRICTIONS OF RECORD UNDER TITLE REPORT PREPARED BY CHICAGO TITLE COMPANY, DATED OCTOBER 23, 2018, ORDER NO. 7101407137-DA

EASEMENTS AFFECTING THAT PORTION OF SAID LAND AND FOR THE PURPOSES STATED HEREIN AND INCIDENTAL PURPOSES AS PROVIDED IN THE FOLLOWING INSTRUMENTS:

- GRANTED TO: REDLANDS WATER COMPANY
 PURPOSE(S): PUBLIC UTILITIES AND INCIDENTAL PURPOSES
 RECORDING DATE: FEBRUARY 24, 1982
 RECORDING NO.: BOOK 28, PAGE 233 OF DEEDS, AND BOOK 29, PAGE 65 OF DEEDS
 NOTES: EASEMENT CANNOT BE LOCATED FROM RECORD

LEGAL DESCRIPTION

LOT 7, BLOCK "C", ACCORDING TO MAP OF ADDITION NO. 7 TO THE SECOND PRELIMINARY MAP OF REDLANDS, IN THE CITY OF REDLANDS, COUNTY OF SAN BERNARDINO, STATE OF CALIFORNIA, AS PER PLAT RECORDED IN BOOK 5 OF MAPS, PAGE 8, RECORDS OF SAID COUNTY.

ADJACENT PROPERTY OWNERS

- | | | | | |
|--|--|---|--|--|
| 01. 0173-242-01
BENTON REVOCABLE LIVING TRUST | 02. 0173-242-08
LOCKWOOD, LESLIE | 03. 0173-242-09
CHAPARRO, GUSTAVO | 04. 0173-242-10
WALCK, ELIZABETH LIVING TRUST | 05. 0173-242-17
O'DONNELL TRUST |
| 06. 0173-242-18
NEWBERRY FAMILY TRUST | 07. 0173-231-12
DEDEOS, MATTHEW | 08. 0173-231-13
CONREY TRUST | 09. 0173-231-17
CARLSON FAMILY TRUST | 10. 0173-231-18
SWEET, STUART |
| 11. 0173-231-09
STRUNK, TIMOTHY | 12. 0173-222-10
STEWART, JOHN | 13. 0173-222-09
ALVAREZ, SERGIO | 14. 0173-221-17
DEAN, CHRISTOPHER & JOYCE | 15. 0173-221-18
COLE, MARY ELIZABETH LIVING TRUST |
| 16. 0173-221-07
CAMP COLE FAMILY TRUST | 17. 0173-151-35
JOHNSON, GREG R & DJ LEPPER-JOHNSON | 18. 0173-151-62
MCGLOIN FAMILY TRUST | 19. 0173-152-03
MELZER, ERICH & MARJORIE | 20. 0173-152-02
SWARM, ORVAL & MARJORIE |

SLOPE PLANTING AND EROSION CONTROL NOTE

FACES OF FINISHED CUT AND FILL SLOPES SHALL BE PREPARED AND MAINTAINED TO CONTROL AGAINST EROSION. DEVELOPER INTENDS TO PROVIDE ADEQUATE EROSION CONTROL AND PROTECTION FOR THE SLOPES PER CALIFORNIA SWPPP AND WATER QUALITY STANDARDS

LEGEND	ABBREVIATIONS	NTS	NOT TO SCALE
EX. 5' CONTOUR	CB	CATCH BASIN	HP
EX. 1' CONTOUR	CONC	CONCRETE	REF
ASPHALT PAVEMENT	CONSTR	CONSTRUCTION	REV
EXISTING STRUCTURE	CLF	CHAIN LINK FENCE	ST
CITRUS TREE	DWY	DRIVEWAY	SW
CHAIN LINK FENCE	ELEV	ELEVATION	TC
HOG WIRE FENCE	EG	EXISTING GRADE	TD
EXISTING OVERHEAD UTILITY LINES	EX	EXISTING	TG
EXISTING WATER MAIN (SIZE AS SHOWN)	FG	FINISH GRADE	TF
EXISTING SEWER (SIZE AS SHOWN)	FH	FIRE HYDRANT	TTE
EXISTING FIRE HYDRANT	F/L	FLOWLINE	TW
EXISTING POWER POLE	GB	GRADE BREAK	TRW
PROPOSED LED STREET LIGHT	HP	HIGH POINT	O.C.
PROPOSED ACORN STREET LIGHT	INV	INVERT	WLY
	MIN	MINIMUM	W/W
	MAX	MAXIMUM	WV
	NG	NATURAL GROUND	
	R/W	RIGHT OF WAY	
	PAE	PUBLIC ACCESS EASEMENT	
	PL	PROPERTY LINE	

TYPICAL STREET SECTIONS
 NOT TO SCALE

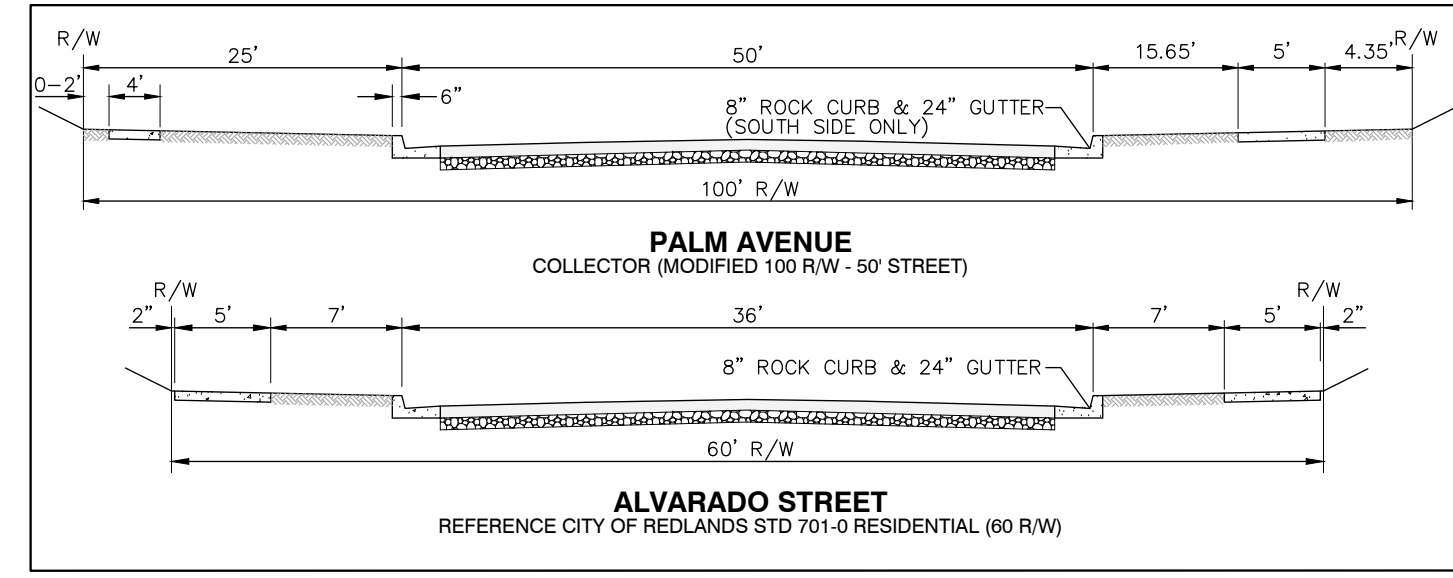

VICINITY MAP

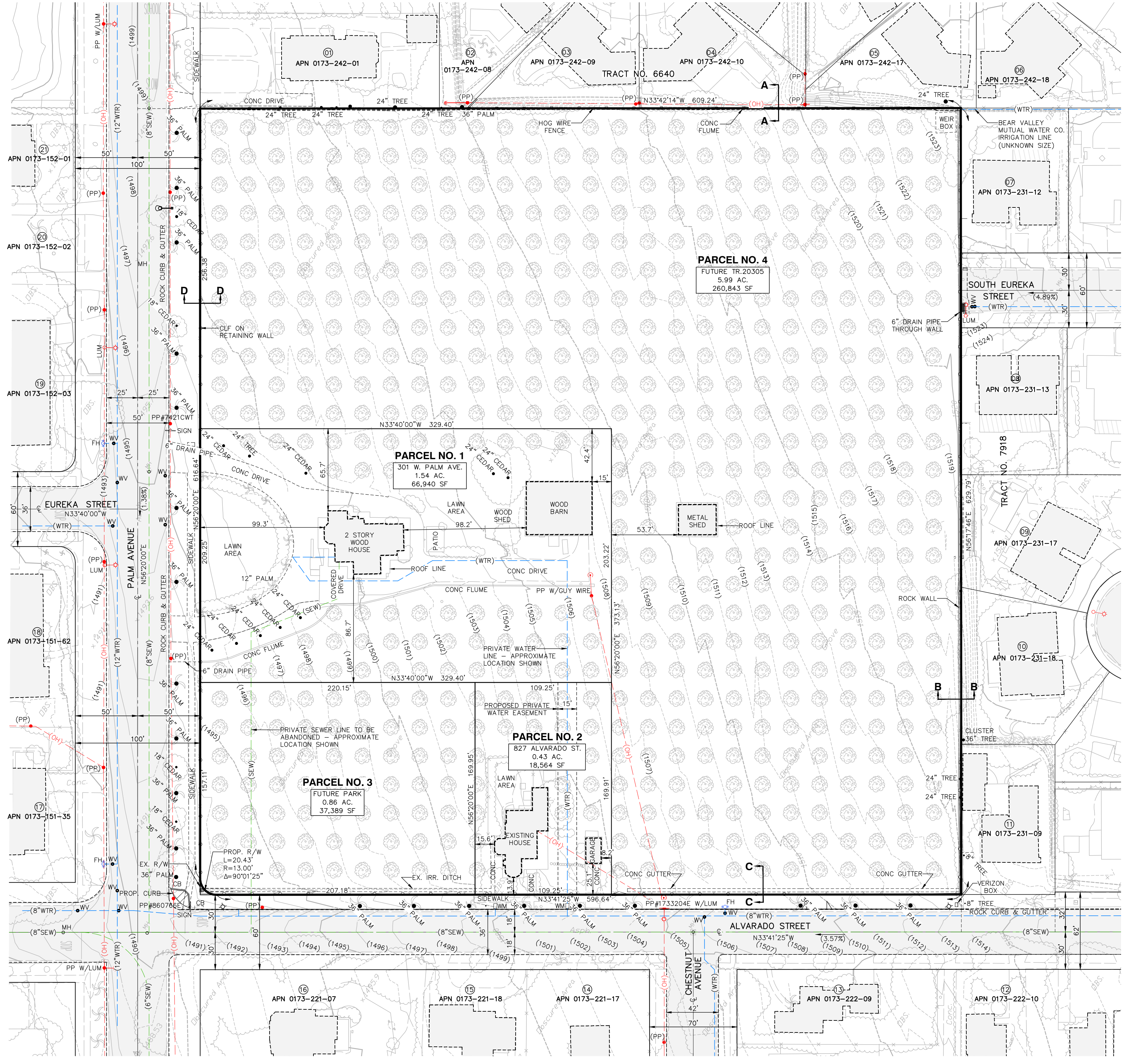
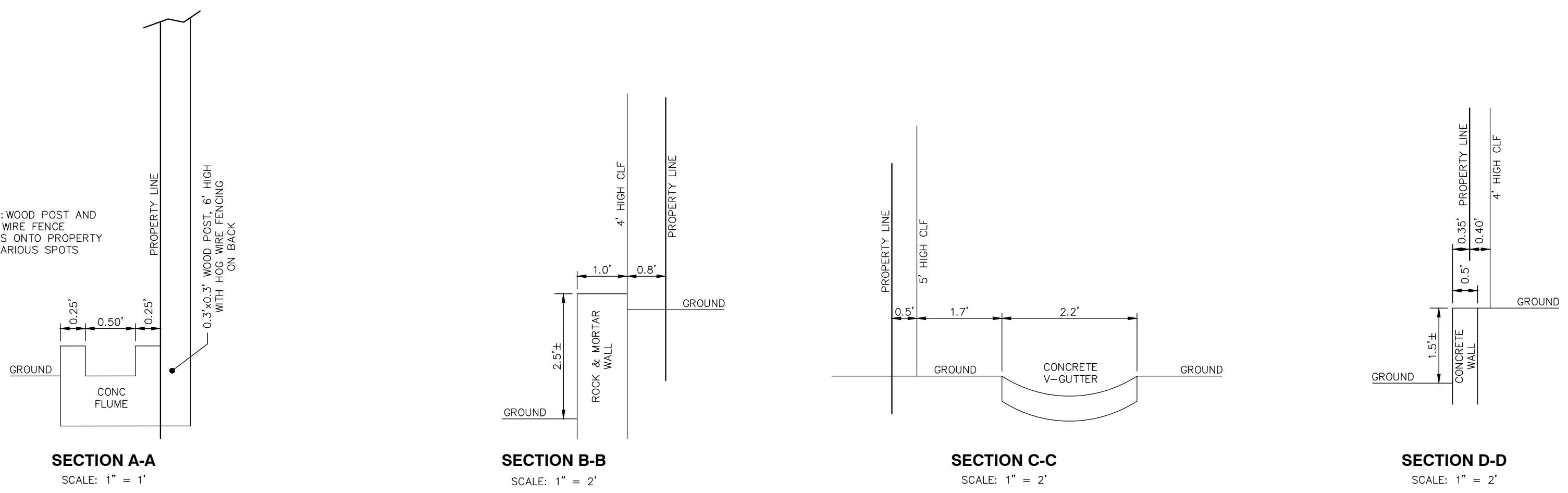
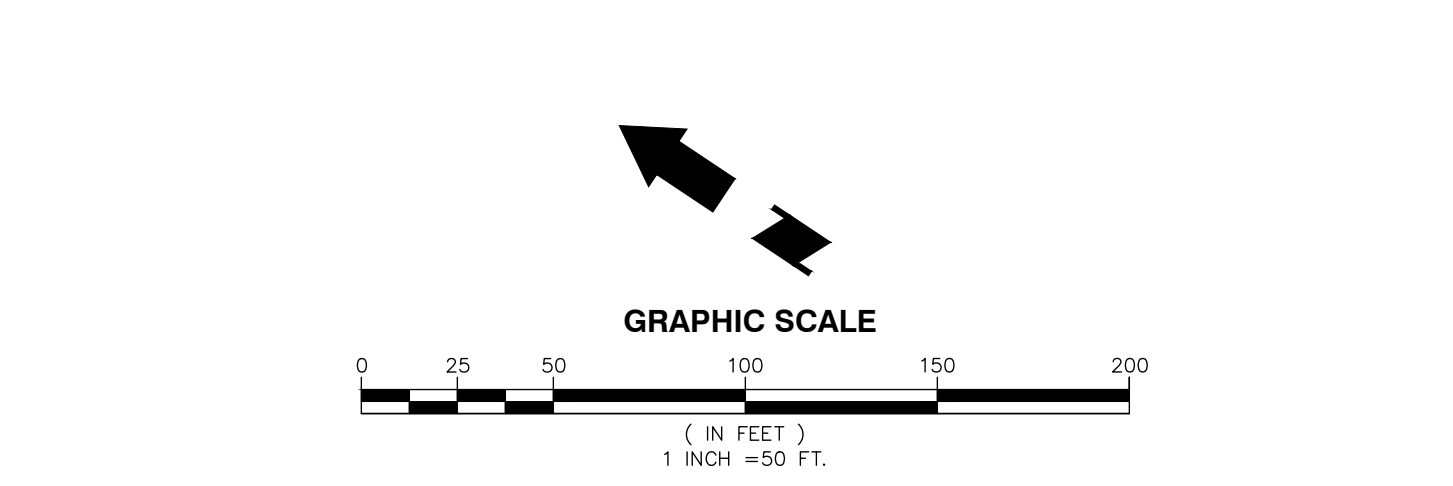
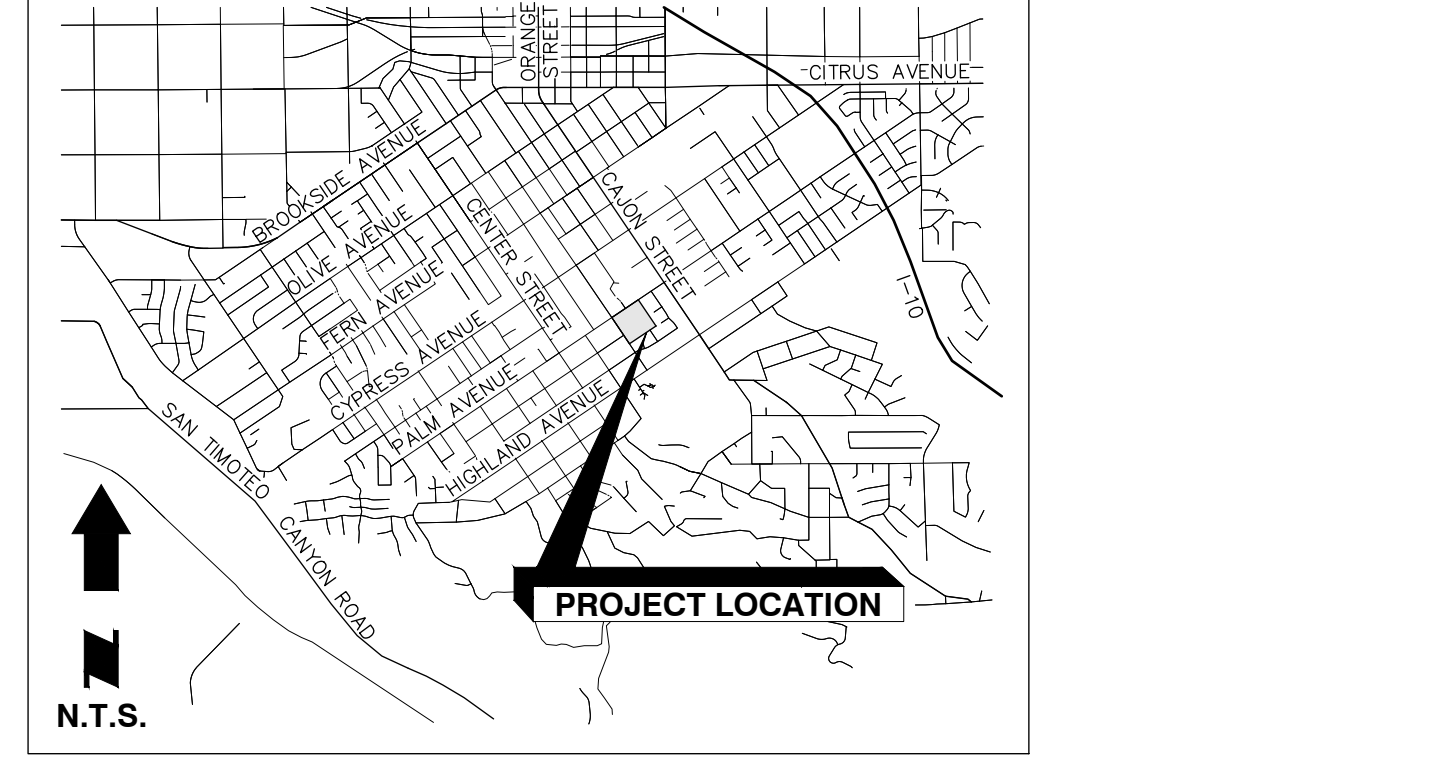

Attachment D

TENTATIVE TRACT MAP No. 20305-PRD

APN 0173-231-05 (301 WEST PALM AVE.)

APPLICANT

DIVERSIFIED PACIFIC COMMUNITIES
10621 CIVIC CENTER DRIVE
RANCHO CUCAMONGA, CA 91730
PH: (909) 481-1150
FAX: (909) 481-1151

CIVIL ENGINEER

HOKS & HARTWICK, INC.
37 EAST OLIVE AVE., SUITE C
REDLANDS, CA 92373
PH: (909) 793-2257

MAP PREPARED BY:

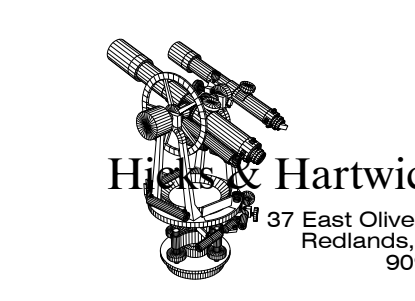

EASEMENTS AND RIGHTS

EASEMENTS AND RESTRICTIONS OF RECORD UNDER TITLE REPORT PREPARED BY CHICAGO TITLE COMPANY, DATED OCTOBER 23, 2016, ORDER NO. 7101407137-DA
EASEMENTS AFFECTING THAT PORTION OF SAID LAND AND FOR THE PURPOSES STATED HEREIN AND INCIDENTAL PURPOSES AS PROVIDED IN THE FOLLOWING INSTRUMENTS:
1. GRANTED TO REDELANDS WATER COMPANY PUBLIC UTILITIES AND INCIDENTAL PURPOSES
PURPOSE(S) FEBRUARY 24, 1982
RECORDING DATE BOOK 28, PAGE 233 OF DEEDS, AND BOOK 29, PAGE 65 OF DEEDS
NOTES EASEMENT CANNOT BE LOCATED FROM RECORD

LEGAL DESCRIPTION

LOT 7, BLOCK "K", ACCORDING TO MAP OF ADDITION NO. 7 TO THE SECOND PRELIMINARY MAP OF REDLANDS, IN THE CITY OF REDLANDS, COUNTY OF SAN BERNARDINO, STATE OF CALIFORNIA, AS PER PLAT RECORDED IN BOOK 5 OF MAPS, PAGE 8, RECORDS OF SAID COUNTY.

ADJACENT PROPERTY OWNERS

- 01. 0173-242-01 BENTON REVOCABLE LIVING TRUST
- 02. 0173-242-08 LOCKWOOD, LESLIE
- 03. 0173-242-09 CHAPARRO, GUSTAVO
- 04. 0173-242-10 WALCK, ELLIZABETH LIVING TRUST
- 05. 0173-242-17 O DONNELL TRUST
- 06. 0173-242-18 NEWBERRY FAMILY TRUST
- 07. 0173-231-12 DEDEDES, MATTHEW
- 08. 0173-231-13 CONREY TRUST
- 09. 0173-231-17 CARLSON FAMILY TRUST
- 10. 0173-231-18 SWEET, STUART
- 11. 0173-231-09 STRUNK, TIMOTHY
- 12. 0173-222-10 STEWARD, JOHN
- 13. 0173-222-09 ALVAREZ, SERGIO
- 14. 0173-221-17 DEAN, CHRISTOPHER & JOYCE
- 15. 0173-221-07 CAMP COLE FAMILY TRUST
- 16. 0173-151-62 JOHNSON, GREG R & DJ LESPER-JOHNSON
- 17. 0173-151-35 JOHNSON, GREG R & DJ LESPER-JOHNSON
- 18. 0173-151-62 MCCLON FAMILY TRUST
- 19. 0173-152-03 MELZER, ERICH & MARJORIE
- 20. 0173-152-02 SWARM, ORVAL & MARJORIE
- 21. 0173-152-01 LANGRETH, JAMES LIVING TRUST

SLOPE PLANTING AND EROSION CONTROL NOTE

FACES OF FINISHED CUT AND FILL SLOPES SHALL BE PREPARED AND MAINTAINED TO CONTROL AGAINST EROSION. DEVELOPER INTENDS TO PROVIDE ADEQUATE EROSION CONTROL AND PROTECTION FOR THE SLOPES PER CALIFORNIA SWPPP AND WATER QUALITY STANDARDS

OWNERSHIP AND MAINTENANCE RESPONSIBILITY STATEMENT

OWNERSHIP AND MAINTENANCE RESPONSIBILITY FOR THE PROJECT DEVELOPMENT PARTS ARE PROPOSED AS NOTED:
ITEM RESPONSIBLE PARTY
PRIVATE STREET 'A' HOME OWNER'S ASSOCIATION
OPEN SPACE LOTS 'A'-D' HOME OWNER'S ASSOCIATION
STREET 'A' STORM DRAIN HOME OWNER'S ASSOCIATION
PARCELS 1 & 2 LOT OWNERS
LOTS 1-30 LOT OWNERS
CITY PARK - PUBLIC PARK CITY OF REDLANDS
PALM AVENUE CITY OF REDLANDS
ALVARADO STREET CITY OF REDLANDS
STREET 'A' SEWER & WATER CITY OF REDLANDS

TYPICAL STREET SECTIONS

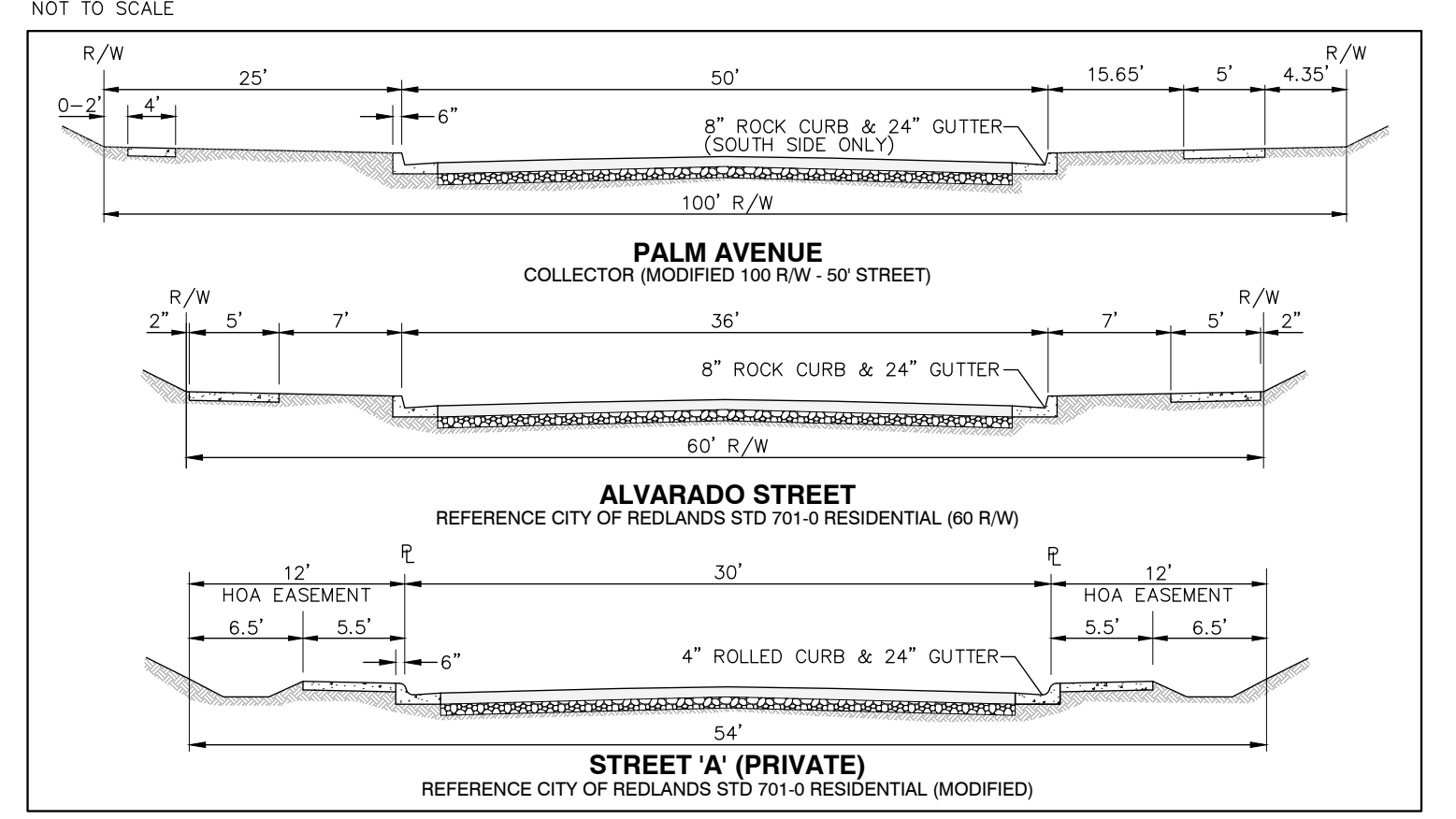

LEGEND

- EX. 5' CONTOUR
- EX. 1' CONTOUR
- PROP. 5' CONTOUR
- PROP. 1' CONTOUR
- DAYLIGHT LINE
- PROP. WALL
- CHAIN LINK FENCE
- ASPHALT PAVEMENT
- CONCRETE
- OPEN SPACE & LANDSCAPING
- 2:1 SLOPE OR LESS
- VEGETATED SWALE
- CONSERVATION EASEMENT
- EMERGENCY ACCESS & UTILITY EASEMENT
- XX LOT NUMBER
- X,XXX SF LOT AREA
- 00.00 PAD ELEVATION
- WTR PROPOSED WATER MAIN (SIZE AS SHOWN)
- SEW PROPOSED SEWER (SIZE AS SHOWN)
- WTR EXISTING WATER MAIN (SIZE AS SHOWN)
- SEW EXISTING SEWER (SIZE AS SHOWN)
- EXISTING STORM DRAIN (SIZE AS SHOWN)
- EXISTING UNDERGROUND UTILITY AS SHOWN
- EXISTING POWER POLE
- OVERHEAD UTILITY LINES
- PROPOSED FIRE HYDRANT
- PROPOSED STORM DRAIN PIPE
- WATER VALVE
- EXISTING FIRE HYDRANT
- PROPOSED LED STREET LIGHT
- PROPOSED ACCORN STREET LIGHT
- FLOWLINE
- APN ASSESSOR PARCEL NUMBER
- CL CENTERLINE
- DWY DRIVEWAY
- ELEV ELEVATION
- EG EXISTING GRADE
- EX EXISTING
- FG FINISH GRADE
- FL FLOWLINE
- HP HIGH POINT
- INV INVERT
- MIN MINIMUM
- MAX MAXIMUM
- NG NATURAL GROUND
- PL PROPERTY LINE
- PROP PROPOSED
- GB GRADE BREAK
- HP HIGH POINT
- R/W RIGHT OF WAY
- REF REFERENCE
- SD STORM DRAIN
- SW SIDEWALK
- TC TOP OF CURB
- TF TOP OF FOOTING
- TG TOP OF GRATE
- TW TOP OF WALL
- TRW TOP OF RETAINING WALL
- W/ WITH

CURVE TABLE

NO	DELTA	RADIUS	LENGTH	NO	DELTA	RADIUS	LENGTH	NO	DELTA	RADIUS	LENGTH
C1	Δ=90°00'00"	25.00'	39.27'	C9	Δ=47°41'42"	20.00'	16.65'	C16	Δ=04°32'33"	1215.00'	96.33'
C2	Δ=20°45'37"	25.00'	9.06'	C10	Δ=104°27'09"	100.00'	18.68'	C17	Δ=04°32'33"	1185.00'	93.95'
C3	Δ=91°02'12"	32.00'	50.84'	C11	Δ=111°24'20"	58.00'	112.77'	C18	Δ=44°32'58"	47.00'	36.54'
C4	Δ=91°02'12"	32.00'	50.84'	C12	Δ=90°00'00"	15.00'	23.56'	C19	Δ=44°32'58"	47.00'	36.54'
C5	Δ=47°41'42"	20.00'	16.65'	C13	Δ=104°27'09"	100.00'	18.68'	C20	Δ=26°05'56"	40.00'	187.87'
C6	Δ=90°00'00"	25.00'	39.27'	C14	Δ=04°32'33"	1185.00'	93.95'	C21	Δ=90°00'00"	25.00'	39.28'
C7	Δ=47°41'42"	20.00'	16.65'	C15	Δ=04°32'33"	1215.00'	96.33'	C22	Δ=90°00'00"	30.00'	47.12'
C8	Δ=91°02'12"	32.00'	50.84'	C23	Δ=04°32'33"	1200.00'	95.14'	C24	Δ=04°32'33"	1200.00'	95.14'

VICINITY MAP

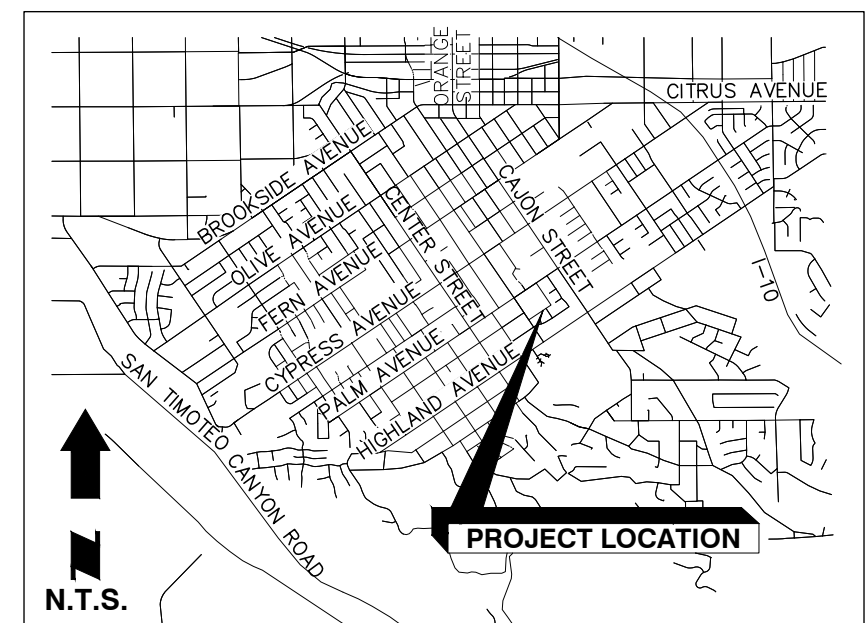

PROJECT AREA CALCULATIONS

TOTAL SITE GROSS AREA:	8.81 AC	383,773 SF
PALM AVE:	0.00 AC	37 SF
TOTAL SUBTRACTED:	0.00 AC	37 SF
NET DEVELOPMENT AREA:	8.81 AC	383,736 SF

PERMANENT OPEN SPACE LOTS

LOT NO.	LOT AREA	LOT USE
LOT A	3,022 SF	OPEN SPACE
LOT B	2,801 SF	OPEN SPACE
LOT C	1,853 SF	OPEN SPACE
LOT D	2,104 SF	OPEN SPACE
PARCEL 1	66,940 SF	EXISTING PALM AVENUE HOUSE (CONSERVATION EASEMENT)
PARCEL 3	37,389 SF	PUBLIC PARK
TOTAL AREA:	114,109 SF (2.62 AC)	

EXCLUDED AREA

EXCLUDED AREA	DESCRIPTION
LOTS A, B, C & D	9,780 SF OPEN SPACE (NOT COMMON AREA)
TOTAL SUBTRACTED AREA:	9,780 SF (0.22 AC)
TOTAL OPEN SPACE:	2,40 AC 104,329 SF

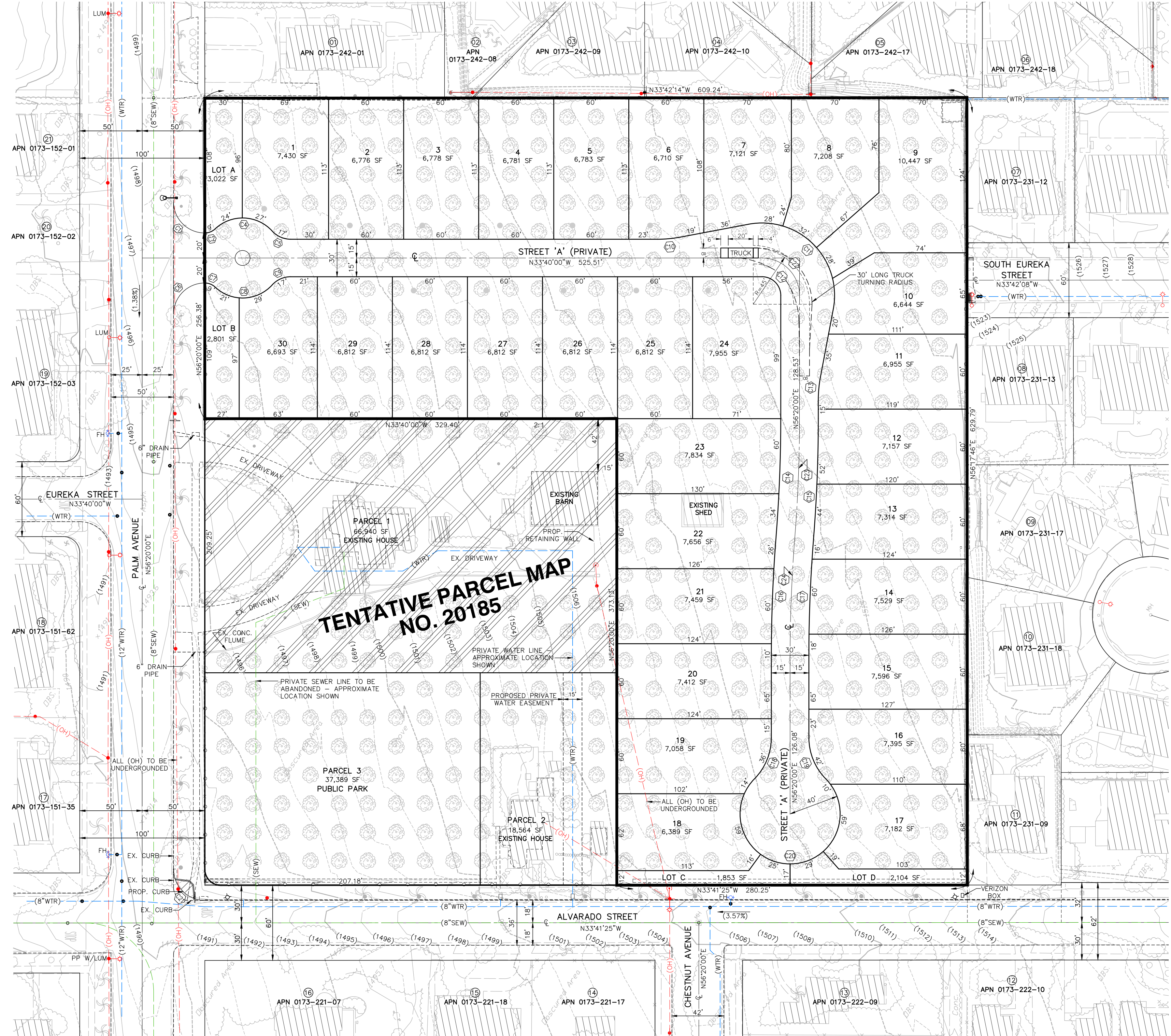

GENERAL NOTES

- 1. TOTAL PROJECT GROSS AREA: 383,773 SF (8.81 AC) (INCLUDES TPM NO. 20185)
- 2. PROJECT CONSISTS OF APN: 0173-231-05
- 3. NUMBER OF LOTS: 30
- 4. DATE PREPARED: 04-13-2020
- 5. NET DEVELOPMENT AREA: 383,736 SF (8.81 AC) (INCLUDES TPM NO. 20185)
- 6. GROSS PROJECT AREA (CALCULATIONS BELOW)
- 7. REQUIRED OPEN SPACE: (20.00%) 76,748 SF (1.76 AC)
- 8. OPEN SPACE PROVIDED: (21.19%) 104,329 SF (2.40 AC)
- 9. OPEN SPACE LOTS/PARCELS: A-D & PCL 1&3 OF TPM NO. 20185
- 10. COVERAGE OF PLANNED RESIDENTIAL DEVELOPMENT STRUCTURES: 2.20 AC (24.90%)

EXHIBIT REQUIREMENTS - PART ONE

- 1. INDEX MAP ON ALL SHEETS: DOES NOT APPLY
- 2. NAME AND ADDRESS OF OWNER/APPLICANT/MAP PREPARER: DELINEATED ON MAP AS REQUIRED
- 3. ACREAGE, NORTH ARROW, VICINITY MAP, DATE OF PREPARATION: DELINEATED ON MAP AS REQUIRED
- 4. EXISTING STRUCTURES AND FEATURES SUCH AS WALLS, BUILDING, AND TREES: DELINEATED ON MAP AS REQUIRED
- 5. DIMENSIONS AND PROPERTY LINES FOR EACH LOT: DELINEATED ON MAP AS REQUIRED
- 6. NAMES OF ADJOINING SUBDIVISIONS AND LANDOWNERS AND ABUTTING LAND USES: DELINEATED ON MAP AS REQUIRED
- 7. LANDS DEDICATED FOR PUBLIC USE: DELINEATED ON MAP AS REQUIRED
- 8. POINTS OF INGRESS AND EGRESS: PALM AVENUE
- 9. PRELIMINARY GRADING, INCLUDING PAD ELEVATIONS AND FLOW LINES WITH LOCATION OF ALL CUT AND FILL SLOPES IDENTIFIED: DELINEATED ON MAP AS REQUIRED

EXHIBIT REQUIREMENTS - PART TWO

- 1. LOCATIONS, NAME, AND WIDTH OF STREETS AND ADJACENT STREETS ALSO SHOW WIDTH OF ALLEYS IF APPLICABLE: DELINEATED ON MAP AS REQUIRED
- 2. PROPOSED STREET GRADES AND GRADES FOR STREETS 100 FEET BEYOND APPLICANT'S PROPERTY: DELINEATED ON MAP AS REQUIRED
- 3. CROSS SECTION OF PROPOSED STREET IMPROVEMENTS IF DIFFERENT FROM STANDARD: DELINEATED ON MAP AS REQUIRED
- 4. LOCATION, DIMENSION, AND PURPOSE OF ANY EASEMENT ON AND ADJACENT TO PROJECT SITE: DELINEATED ON MAP AS REQUIRED
- 5. LOCATION OF EXISTING PUBLIC UTILITIES, CULVERTS, DRAIN PIPES, AND WATER COURSES: DELINEATED ON MAP AS REQUIRED
- 6. APPROXIMATE RADIUS OF CURVES: DELINEATED ON MAP AS REQUIRED
- 7. TOPOGRAPHICAL DATA TO MAKE CLEAR THE EFFECT OF THE PROPOSED 2' CONTOURS AT GRADES 5% OR LESS, 5' CONTOURS AT GRADES OF MORE THAN 5%: SOURCE OF THE CONTOURS SHALL BE STATED ON MAP: DELINEATED ON MAP AS REQUIRED

BENCH MARK

CITY OF REDLANDS BENCH MARK R-82 BRASS DISK IN TOP OF CURB AT THE SE CORNER OF CAJON STREET AND PALM AVENUE, EAST END OF RETURN, ELEVATION = 1317.581

BASIS OF BEARINGS

THE BASIS OF BEARINGS FOR THIS MAP IS DERIVED FROM THE CENTERLINE OF PALM AVENUE SHOWN AS N56°20'00"E ON TRACT NO. 6640, MB 84/6-7.

TOPOGRAPHIC MAP NOTE

TOPOGRAPHIC MAP PREPARED BY: INLAND AERIAL SURVEYS, INC.

SOILS ENGINEER / GEOLOGIST

GEOLOGICAL INVESTIGATION CONDUCTED BY: PETRA GEOSCIENCES INC. JOB NO. 18-430, DATED FEBRUARY 15, 2019

PUBLIC UTILITY COMPANIES

- GAS: SOUTHERN CALIFORNIA GAS CO. 1981 W. LUGONIA AVENUE, REDLANDS, CA 92374-9720 (800) 427-2200
- WATER: CITY OF REDLANDS P.O. BOX 6905 1722 ORANGE TREE LANE, REDLANDS, CA 92373-0903 (909) 798-7516
- ELECTRIC: SOUTHERN CALIFORNIA EDISON CO. 287 TENNESSEE STREET, REDLANDS, CA 92373 (909) 307-6731
- SEWER: CITY OF REDLANDS P.O. BOX 6905 1722 ORANGE TREE LANE, REDLANDS, CA 92373-0903 (909) 798-7516
- TELEPHONE: VERIZON INC. 1500 CRAFTON AVENUE, MENTONE, CA 92359 (909) 794-8210

TYPICAL LOT DRAINAGE

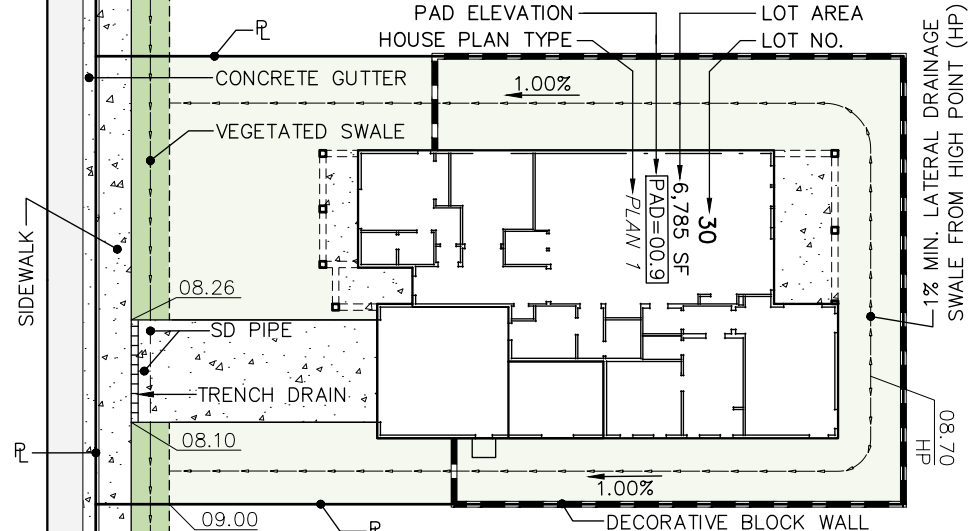

LOT COVERAGE

LOT NO.	LOT AREA	LOT COVERAGE	LOT NO.	LOT AREA	LOT COVERAGE
1	7,430 SF	2,795 SF	16	7,395 SF	3,112 SF
2	6,776 SF	3,112 SF	17	7,182 SF	2,795 SF
3	6,776 SF	3,452 SF	18	6,389 SF	2,795 SF
4	6,781 SF	3,112 SF	19	7,058 SF	3,112 SF
5	6,783 SF	3,452 SF	20	7,412 SF	3,452 SF
6	6,710 SF	3,112 SF	21	7,459 SF	3,112 SF
7	7,121 SF	2,795 SF	22	7,656 SF	3,452 SF
8	7,208 SF	2,795 SF	23	7,834 SF	3,452 SF
9	10,447 SF	3,452 SF	24	7,955 SF	3,452 SF
10	6,644 SF	2,795 SF	25	6,812 SF	3,112 SF
11	6,955 SF	3,112 SF	26	6,812 SF	3,452 SF
12	7,157 SF	3,452 SF	27	6,812 SF	3,452 SF
13	7,314 SF	3,112 SF	28	6,812 SF	3,112 SF
14	7,529 SF	3,452 SF	29	6,812 SF	3,452 SF
15	7,596 SF	3,452 SF	30	6,693 SF	2,795 SF
TOTAL LOT COVERAGE AREA:		2.20 AC	95,561 SF		

VEGETATED SWALE - TYPICAL STREET 'A' PARKWAY (SHEET 2)

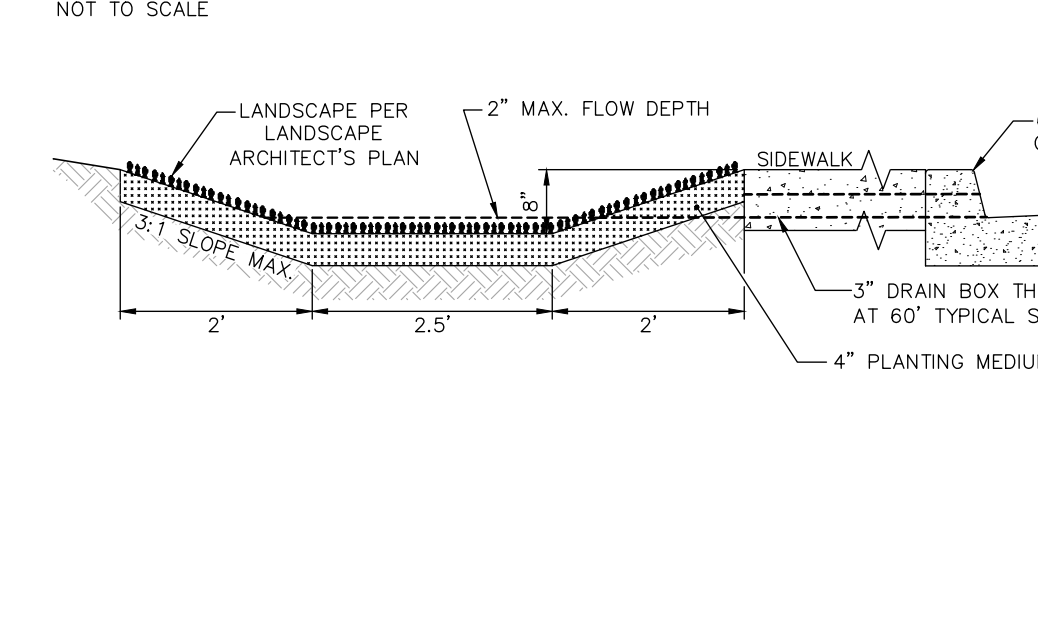

SHEET INDEX

SHEET NO.	DESCRIPTION
1	TENTATIVE TRACT MAP & GENERAL NOTES
2	PRELIMINARY GRADING & PLOT PLAN

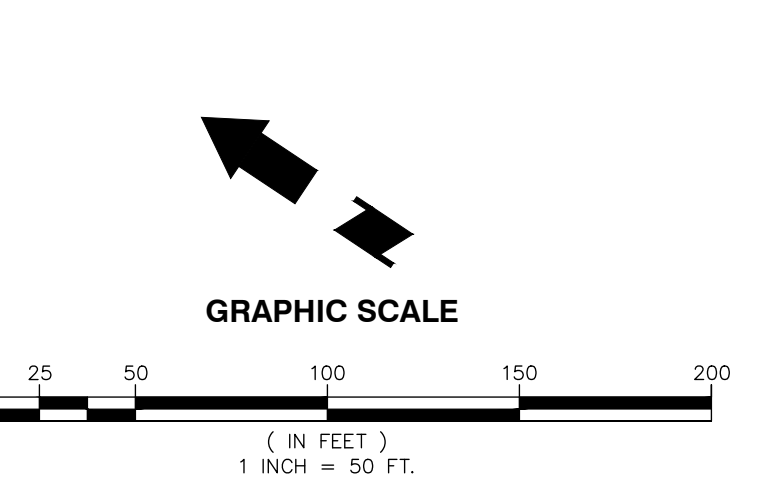

TENTATIVE TRACT MAP No. 20305-PRD

PRELIMINARY GRADING & PLOT PLAN

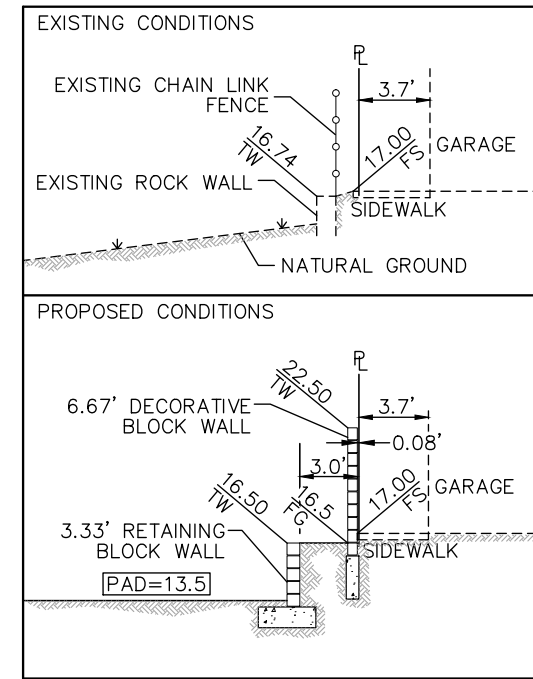

SECTION A-A

SCALE: 1" = 10'

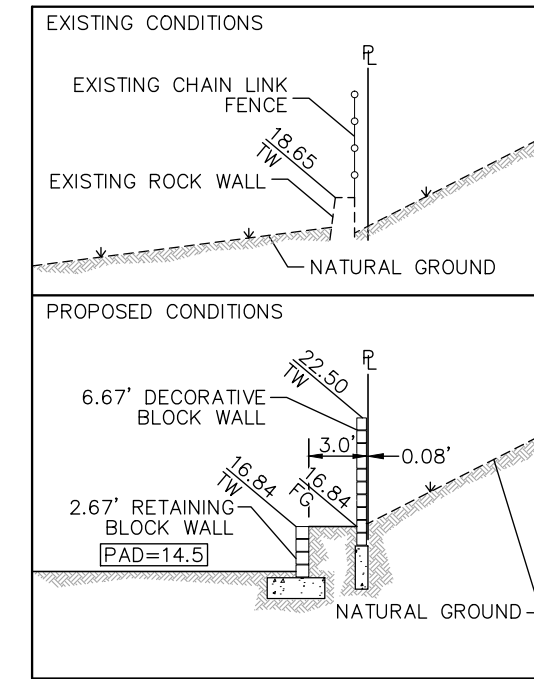

SECTION B-B

SCALE: 1" = 10'

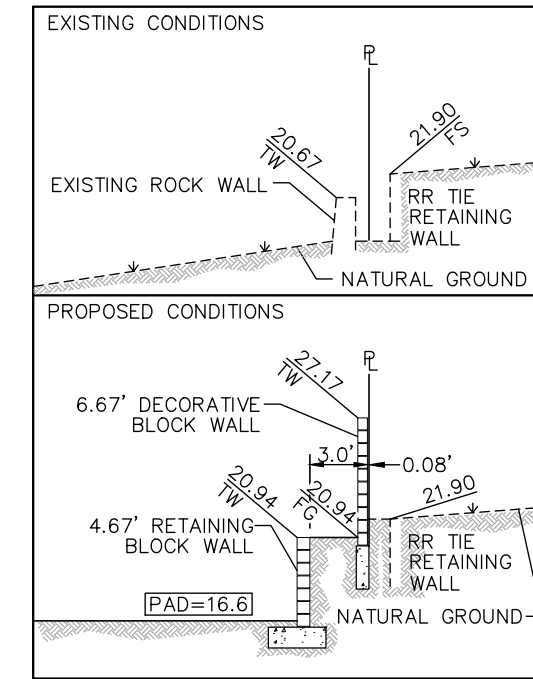

SECTION C-C

SCALE: 1" = 10'

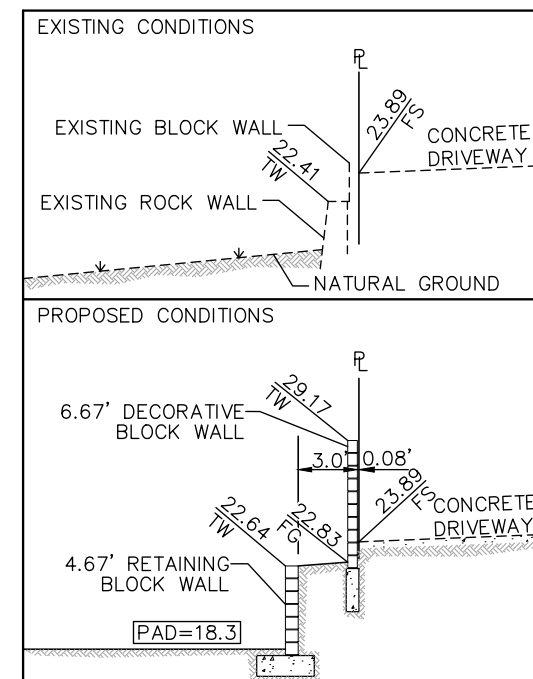

SECTION D-D

SCALE: 1" = 10'

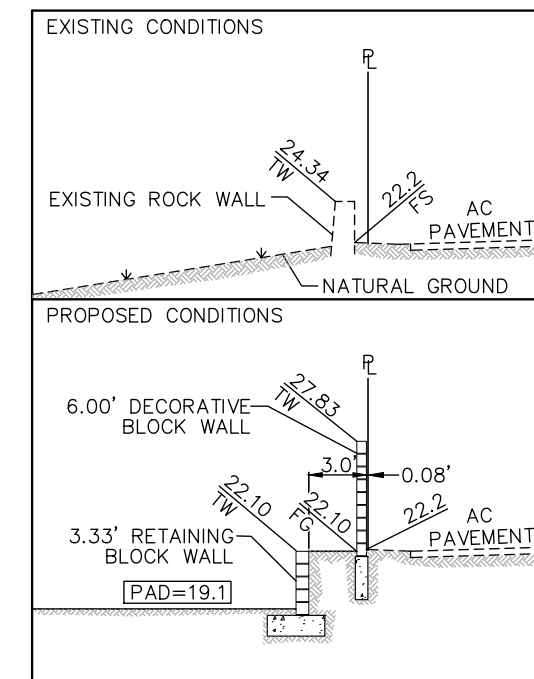

SECTION E-E

SCALE: 1" = 10'

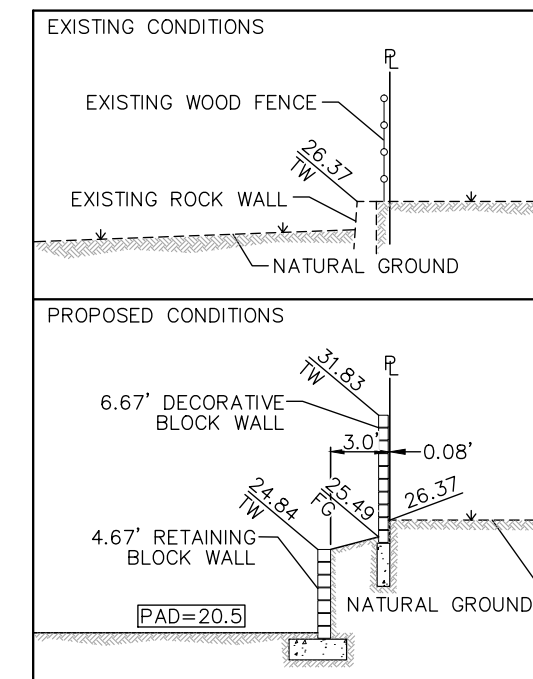

SECTION F-F

SCALE: 1" = 10'

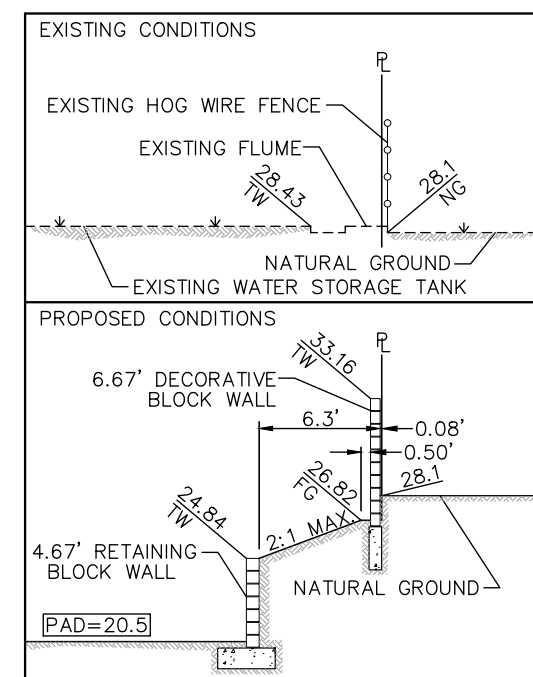

SECTION G-G

SCALE: 1" = 10'

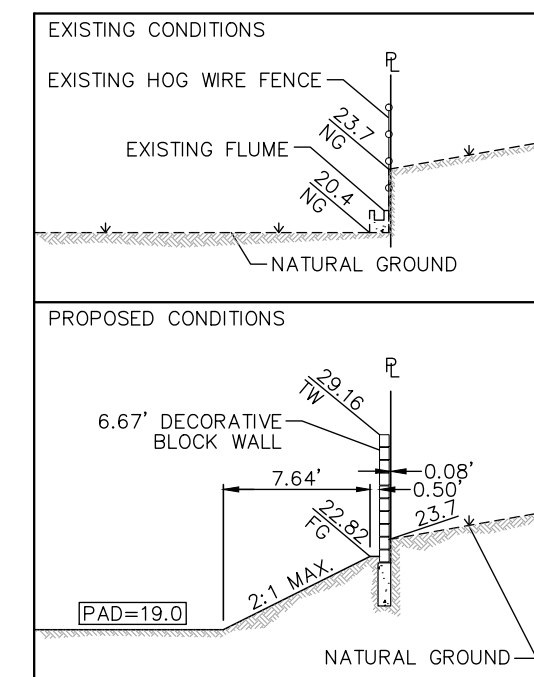

SECTION H-H

SCALE: 1" = 10'

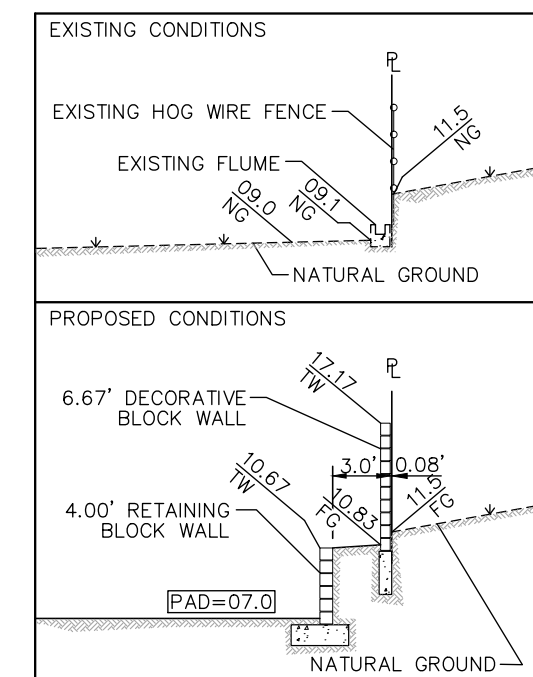

SECTION I-I

SCALE: 1" = 10'

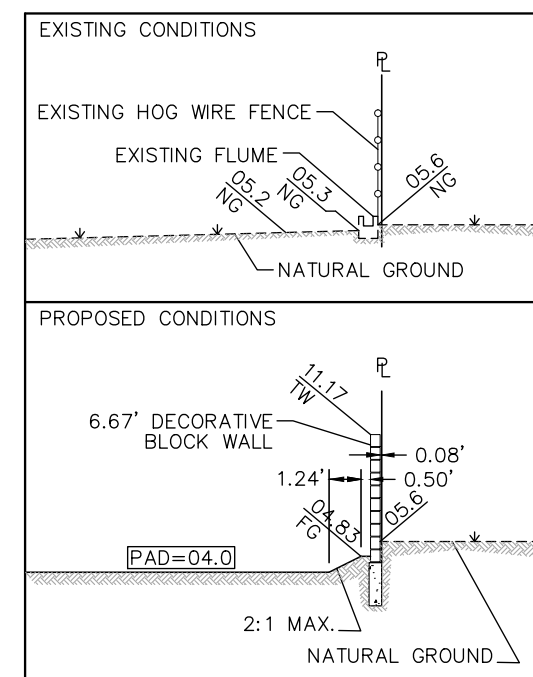

SECTION J-J

SCALE: 1" = 10'

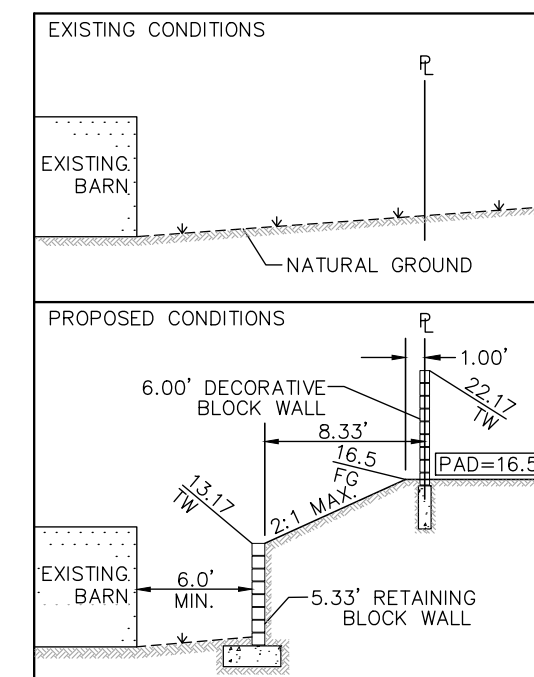

SECTION K-K

SCALE: 1" = 10'

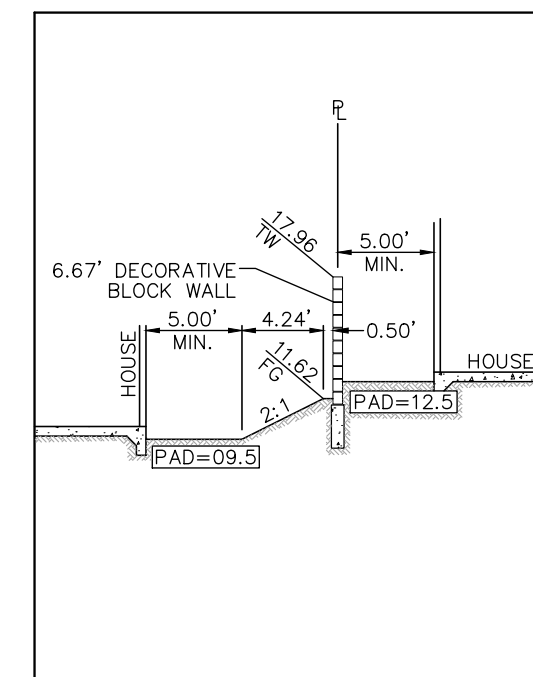

SECTION L-L (TYP. SIDEYARD)

SCALE: 1" = 10'

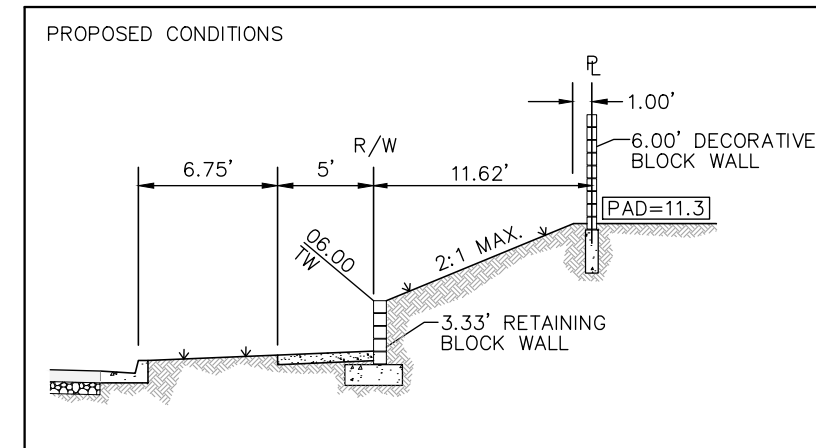

SECTION M-M

SCALE: 1" = 10'

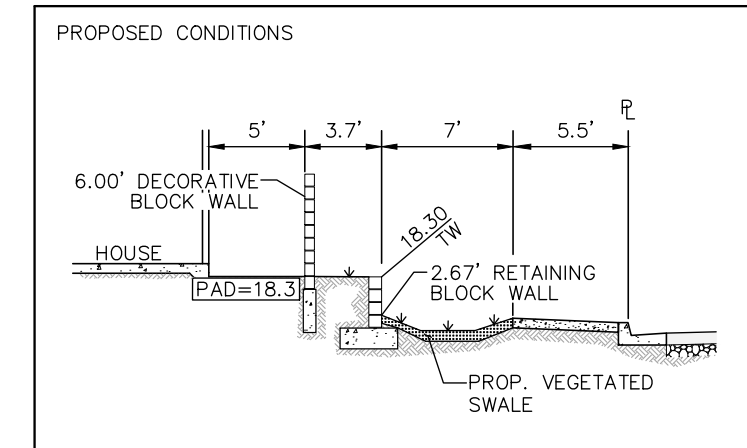

SECTION N-N

SCALE: 1" = 10'

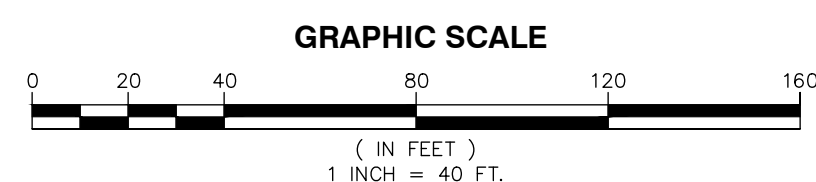

Attachment E

WEST PALM AVENUE

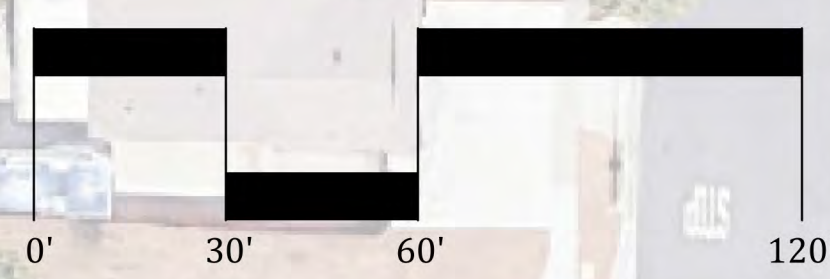
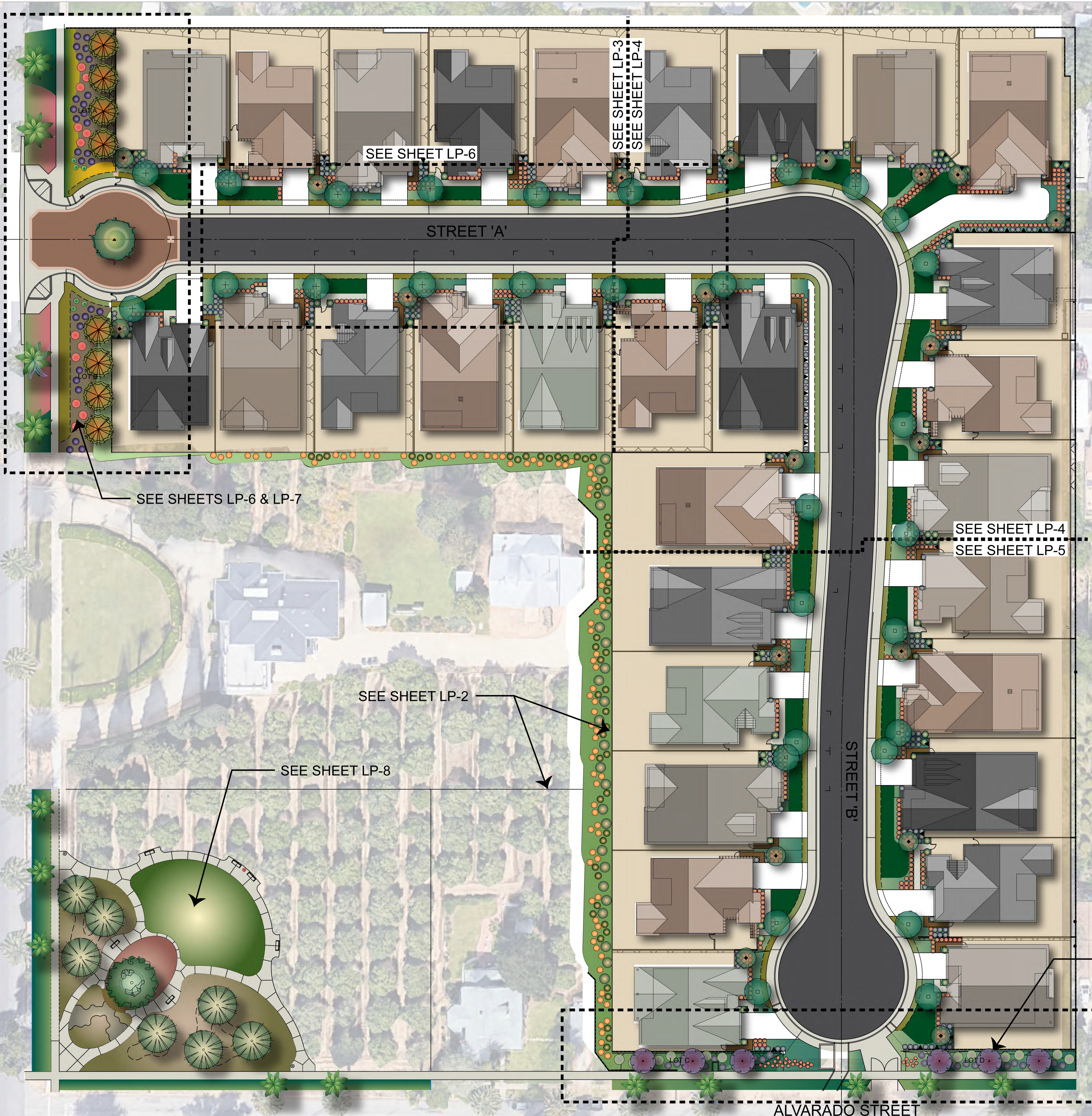

OVERALL LANDSCAPE EXHIBIT
301 WEST PALM AVENUE
 DIVERSIFIED PACIFIC



LP-1
 SHEET 1 OF 8