

## Drainage Piping

### Notes

- This information is intended to provide general guidance on the selection and assembly of drainage piping and fittings as they are commonly available to the home owner in retail outlets. It is not a complete rendering of all the materials and methods allowed by the California Plumbing Code (CPC). This material assumes a single family residence of modest size with no more than three toilets. The use of ABS or PVC plastic pipe and fittings is assumed although not necessarily required by the CPC.
- Use only fittings and fixtures that bare the "UPC" symbol
- Slope drain lines  $\frac{1}{4}$ " per foot or more.
- Vent piping may be dead level but must have no sags or dips that can hold water. They must drain back to the trap that they serve.
- Never use the vent from one fixture as the drain for another fixture unless you follow the very specific rules set forth in the CPC under combination waste and vent systems.
- Never connect a dish washer down-stream of a garbage disposer. Always connect a dish washer through an approved air gap fitting.
- Extend vents at least 6" above the roof.
- Vent type fitting may never be used in a drain. Drainage fittings may be used in a vent. See Note 4.

### Typical Laundry Stand Pipe

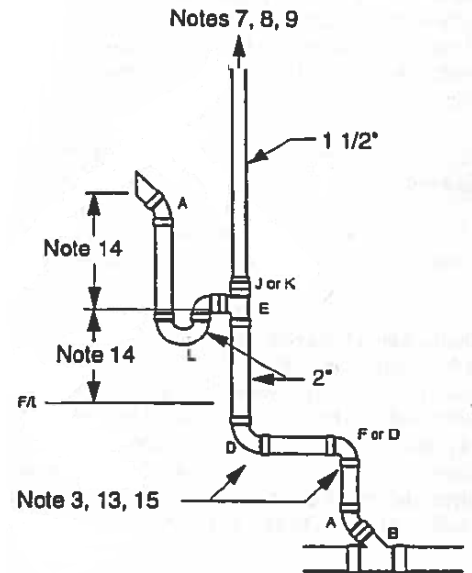

### Typical Kitchen Drainage

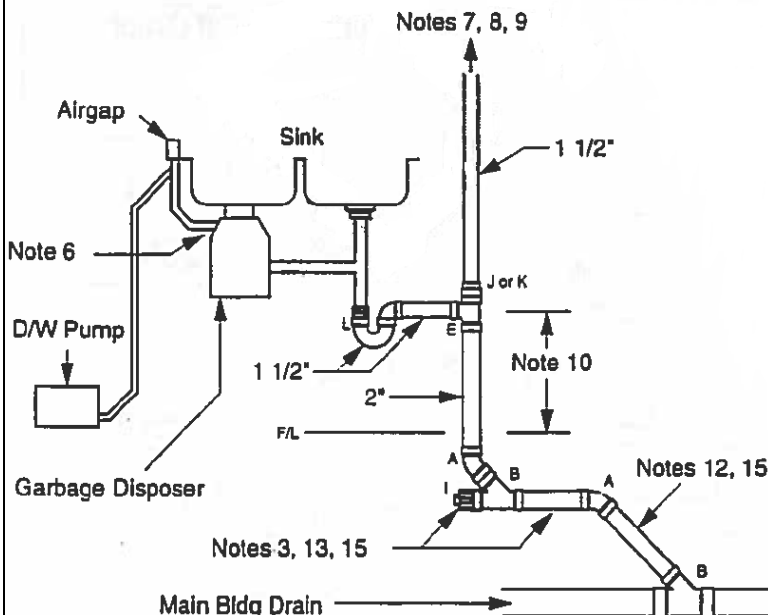

9. Extend vents through the roof undiminished in size. They may generally be tied in with other vents. A 2" vent will serve all three fixtures of the typical bathroom. A 1 1/2" vent will serve the typical kitchen. However, vents must be extended through the roof such that the total area of the vents through the roof is at least equal to the area of the main building drain. The area of a 1 1/2" pipe is 1.77 sq. in., of a 2" pipe is 3.14 sq. in. and of a 3" pipe is 7.07 sq. in.

10. Vents should extend vertically to a point 6" above the flood level of the fixture before breaking horizontal or being connected to other vents. Where structural conditions make this impossible the portion of the vent that is below this point must be sloped as a drain and drainage type fittings must be used. See Notes 3, 9 and 15.

11. Shower stalls require a 2" p-trap and the use of an appropriate floor flange or adapter.
12. Strap or support all piping every 4' and at ends and bends.
13. Provide a cleanout at the upstream end of the main building drain and at the upstream ends of any lateral branches more than 5' long. Cleanouts need not be provided above the first floor or in drains that slope 72 degrees or less from vertical.
14. Install clothes washer p-trap between 6" and 18" above finished floor. Stand pipe must be between 18" and 30" long.
15. Long sweep fittings must be used where waster leaves the fitting horizontally. Note that anything less than 45 degrees from the horizontal is considered horizontal. Long sweep or short sweep fittings may be used where waste leaves the fittings downward but use only sanitary tees where the trap arm enter the drain. See Note 16. Never lay a sanitary tee on its back.
16. Connect vents at a point no lower than the p-trap except at toilets. See diagrams.
17. Where a vent pipe connects to a horizontal drain the vent must be taken off above the center line of the drain. See graphic "A"
18. Drains and vents should be located in the wall appropriately for the fixture being installed. Read the installation instruction. Guidelines for the most typical situations are as follows. Install drain for vanity 16" above floor and centered. For tubs see instructions or work with the tub in place. For toilets install flange 12" from the rear wall, at least 15" from side walls, vanities, etc. and in a space that provides a clear 24" in front of the fixture. For a double kitchen sink with garbage disposer install drain 16" above the floor and 8" off center. For clothes washer standpipes see Note 14.

### Common Pipe Fittings

#### Long Sweep Fittings, See Note 15

- A. 1/8 bend.....
- B. Wye.....
- C. Combi why & 1/8 bend.....
- D. Long sweep 1/4 bend...



#### Short Sweep Fittings, See Note 15

- E. Sanitary tee.....
- F. Short sweep 1/4 bend.....



#### No Sweep or Vent Fittings, See Notes 8 & 15

- G. Vent tee.....
- H. Vent 1/4 bend.....



#### Other Common Fittings

- I. Cleanout.....
- J. Bell reducer.....
- K. Reducer Bushing.....
- L. P-trap.....
- M. Closet Bend.....
- N. Toilet Floor Flange.....



### Typical Bathroom Drains and Vents

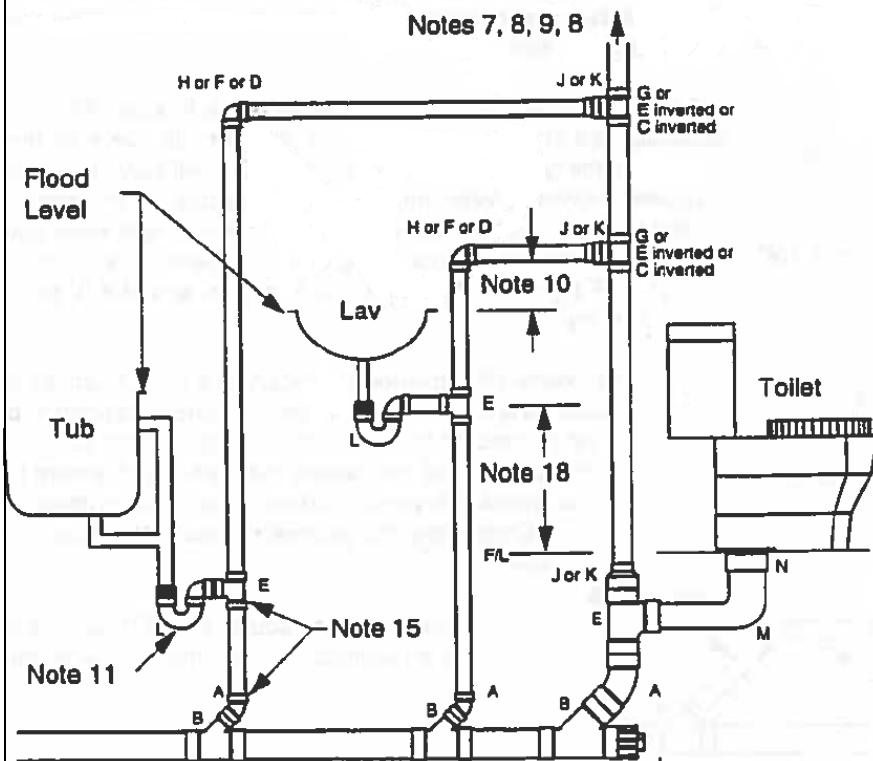

### Vent Take Off Graphic

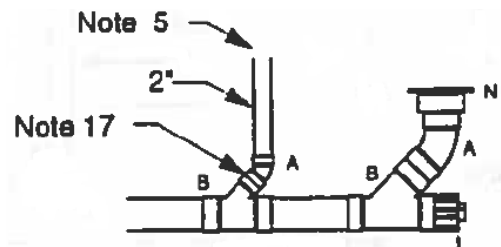
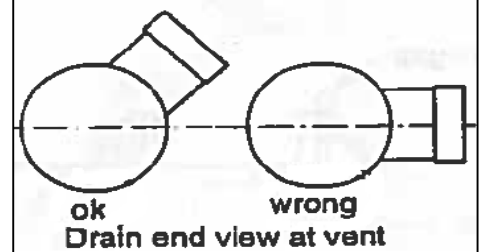

Alt. Toilet Drainage